

Vlinderkleppen



Inhoudsopgave

Materialen	3
Afmetingen Wafer Type (DN 32 - DN 300)	4
Kv waarden en draaimomenten	5

HANDELSMERKEN

De volgende handelsmerken zijn door Dupont geregistreerd:

- Kalrez®
- Viton®
- Teflon®
- Hypalon®
- BUNA-N®

Afmetingen Wafer Type (DN 32 - DN 300)

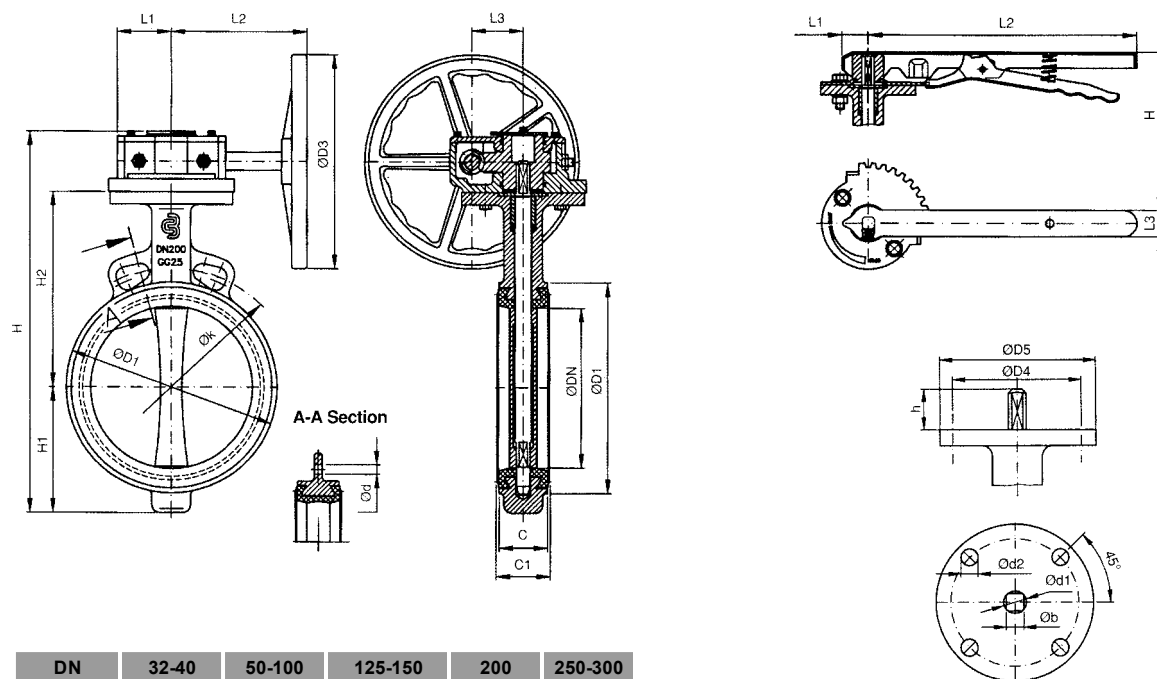

DN	32-40	50-100	125-150	200	250-300
h	32	32	32	45	45
b	11	11	14	17	22
D5	90	90	90	90	135
D4	70	70	70	70	102
d2	10	10	10	10	14
Flensdikte	12	12	12	12	16

PN	DN	32	40	50	65	80	100	125	150	200	250	300
Alle	C	33	33	43	46	46	52	56	56	60	68	78
	H1	67	67	80	89	95	114	127	139	175	203	242
	H2	130	130	140	152	159	178	191	204	238	270	315
PN10	Ød	18	18	18	18	18	18	18	23	23	23	23
	Øk	100	110	125	145	160	180	210	240	295	350	400
PN16	Ød	18	18	18	18	18	18	18	23	23	27	27
	Øk	100	110	125	145	160	180	210	240	295	355	410
ANSI150	Ød	-	16	19	19	19	19	23	23	23	25	25
	Øk	-	98.6	120.7	139.7	152.4	190.5	215.9	241.3	298.4	361.9	431.8
Alle	H	229	229	252	273	286	324	350	373	458	518	602
	L2	266	266	266	266	266	266	266	266	355	505	505
	Kgs	2.3	2.3	3.5	4.0	4.4	6	7.3	8.5	15.8	22.4	32.9

Kv waarden en draaimomenten

F(Nm/bar)

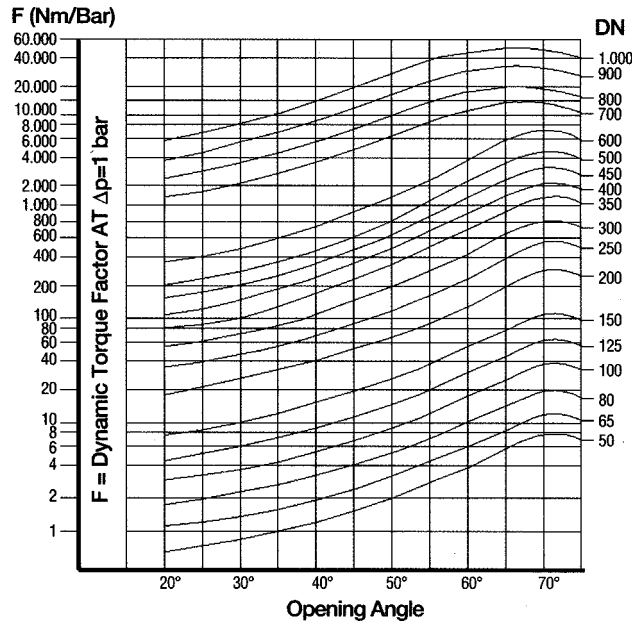

$$T_d = F \times \Delta p \alpha ; [Nm] = [Nm/bar] \times [bar]$$

DN	700	800	900	1000
0 bar	2850	4465	6780	10050
10 bar	3540	5535	8400	12550
16 bar	3955	6180	9370	14050

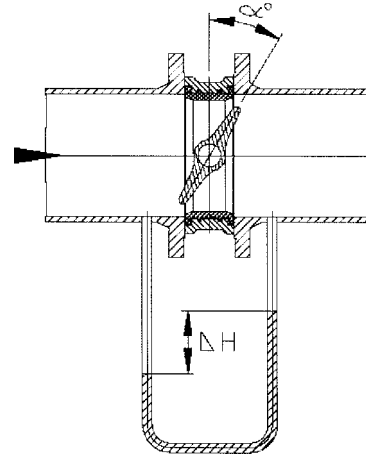

Flow

$$Q = K_v \sqrt{\frac{\Delta p \alpha}{\alpha}} \quad [l/s]$$

$\Delta p \alpha$ (bar) Drukval over de klep bij een bepaalde opening
 α (kg/l) Soortelijk gewicht van de vloeistof

Minimum draaimomenten vanwege wrijving klepblad/zitting

DN	32/40	50	65	80	100	125	150	200	250	300	350	400	450	500	600
0 bar	8	11	16	20	30	46	75	140	200	250	310	480	880	1210	2210
10 bar	9	12	18	26	38	58	90	170	250	320	380	620	1080	1510	2810
16 bar	10	13	19	30	44	65	106	195	280	380	475	705	1220	1690	3135

Kv-waarden

DN α°	90°	80°	70°	60°	50°	40°	30°	20°
50	40	32	20	14	9	5	3	1.4
65	70	55	36	25	15	9	5	2.4
80	110	90	57	38	24	14	8	4
100	180	145	94	63	40	23	12	6
125	320	255	165	110	70	40	25	10
150	470	375	245	165	105	60	35	15
200	790	630	410	275	175	100	55	25
250	1250	1000	650	440	275	155	85	40
300	1800	1440	935	630	395	225	125	60
350	2400	1920	1250	840	530	300	170	80
400	3080	2465	1600	1080	680	390	215	105
450	4150	3320	2160	1450	915	520	290	140
500	5200	4160	2705	1820	1145	655	365	175
600	7100	5680	3690	2485	1560	895	495	240
700	10100	8075	5250	3030	1820	1000	500	200
800	13000	10400	6760	3900	2340	1300	660	260
900	16400	13120	8500	4920	2950	1640	825	330
1000	20700	16560	10765	6210	3725	2070	1040	415